

MULTI-CARTRIDGE HOUSINGS



12 & 22 ROUND CARTRIDGE HOUSINGS

SWT's twelve and twenty-two round multi-cartridge housing models are designed for flow rates up to 600 gpm. Available in a variety of stack configurations, the standard models all feature stainless steel construction with poly-coat finish, easy access covers for quick change-outs, heavy duty mounting legs, and FDA grade Buna-N gaskets. A variety of pipe connection styles and sizes are available to match your application.



FEATURES

- Designed for industrial and commercial filtration needs
- Design pressure: 150 psi (10 bar) @ 300°F (149°C)
- Heavy duty stainless steel construction for durability
- Band clamp or swing bolt closures for quick cartridge change-outs
- Heavy duty mounting legs standard
- Pipe fittings readily accessible for easy installation
- Knife edge seal at both cartridge ends to eliminate by-pass
- Adjustable top plate for more cartridge options
- Available for Double Open End (DOE), 222, or 226 cartridges

OPTIONS & ADD-ONS

Closure Style: V-Band Clamp or Swing Bolt

Material: 304L Stainless Steel or 316L Stainless Steel

Cartridge Type: Double Open Ended (DOE), 222 Style Cartridge (Fin or Flat), or 226 Style Cartridge (Fin or Flat)

Connections: 2" Flange, 3" Flange (Standard for 12 Round Models), 4" Flange (Standard for 22 Round Models), 2" Ferrules, 3" Ferrules, 4" Ferrules, 2" Grooved Fittings, 3" Grooved Fittings, or 4" Grooved Fittings

Finish: Standard Poly Coat, Electro-Polished, Glass Bead, or Passivate

Extras: Gauge Ports, Gauge Ports with Gauges

Gasket: Buna, EPR, Silicone, Viton, or Teflon Encapsulated Silicone



Adjustable top plate accepts variable length cartridges

Part Number	Cartridges			Flow Rate GPM **	Connection Size			Shipping Weight Lb.	
	Number Per Unit	Length Inches *	Maximum Diameter †		Flange Inches	Drain NPT	Vent NPT	Clamp Style	Swing Bolt Style
YH22724	12	20	2.75	168	3	0.5	0.25	86	131
YH22736	12	30	2.75	252	3	0.5	0.25	92	142
YH22748	12	40	2.75	336	3	0.5	0.25	100	150
YH22766	22	30	2.625	462	4	0.5	0.5	140	205
YH22788	22	40	2.625	616	4	0.5	0.5	165	225

* Equivalent lengths accepted: 10 inch = (9.75 or 10 inch); 20 inch = (19.5 or 20 inch); 30 inch = (29.25 or 30 inch); 40 inch = (39 or 40 inch)

** Based on 7 gpm per 10 inch length with a 25 micron wound cartridge at 2 psid clean and a viscosity of 1 cps. Flow rates are for guidelines only. Actual flow rates are based on fluid, viscosity, cartridge type, micron ratings, and other factors.

† When using 222 or 226 adapters with the 22 Round models you must change it to a 21 Round max cartridge O.D. 2.75 inch.

MULTI-CARTRIDGE HOUSINGS



12 & 22 ROUND CARTRIDGE HOUSINGS

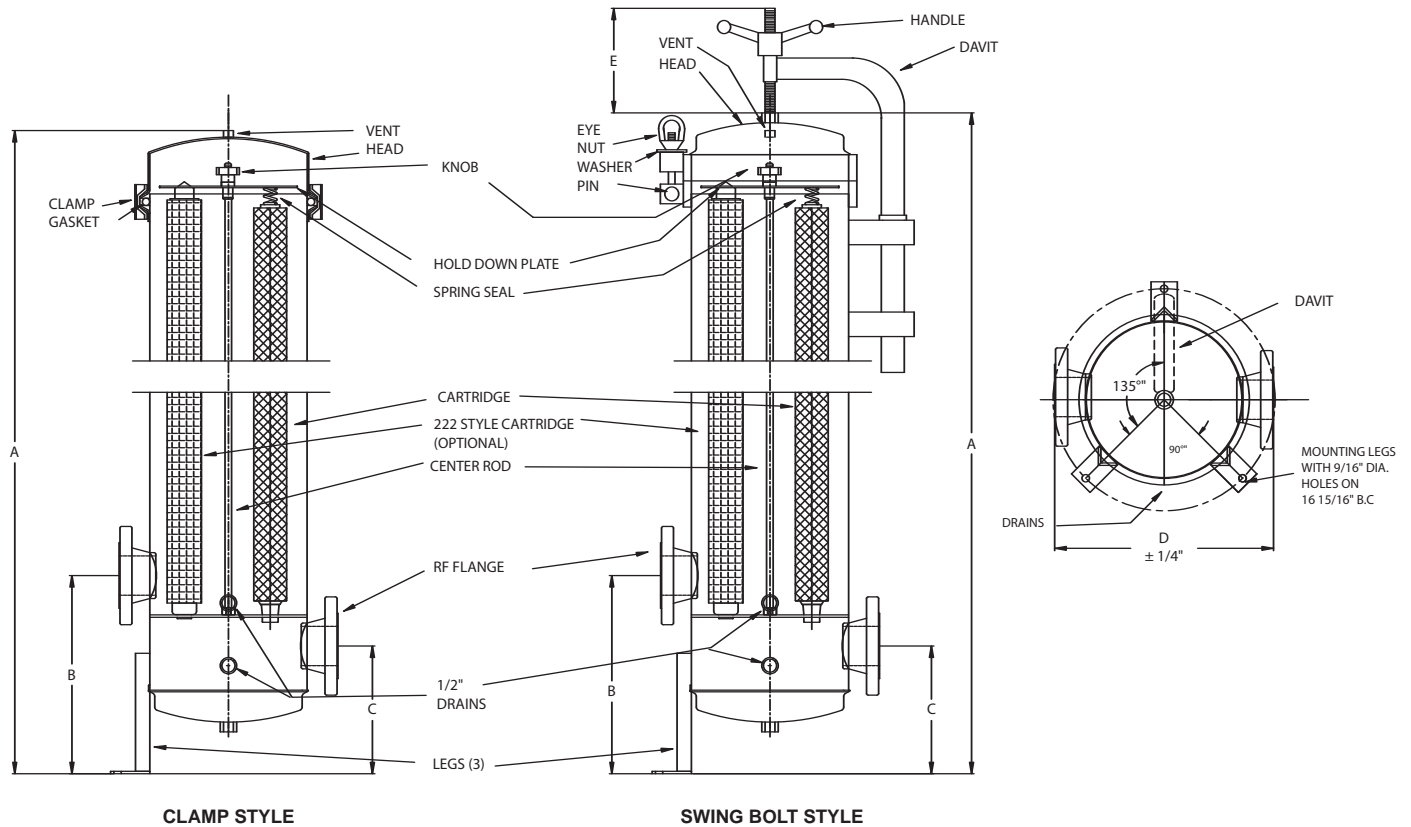

PART NUMBER	CLAMP STYLE	SWING BOLT STYLE	B	C	D	E
	DIM. A	DIM. A				
YH22724	20-1/2"	40-1/2"	15-1/8"	9-3/4"	16-11/16"	8"
YH22736	49-1/2"	50-1/2"	15-1/8"	9-3/4"	16-11/16"	8"
YH22748	59-1/2"	60-1/2"	15-1/8"	9-3/4"	16-11/16"	8"
YH22766	50-3/16"	50-3/16"	15-1/4"	9-1/2"	21"	10"
YH22788	60-3/16"	50-3/16"	15-1/4"	9-1/2"	21"	10"



Gauge port assembly with mounting legs



Electro-polish